









TECHNISCHE SPEZIFIKATIONEN



Typ		Benötigte Ladefläche des LKW (Mindestmaße)		LKW Nutzlast in Tonnen	Kapazität ca. kg	Kapazität ca. m ³	Gewicht der Basismaschine in kg	Länge in mm	Breite in mm	Höhe in mm	Gasverbrauch ca. kg/h
		Länge mm	Breite mm								
ATC 25M		1900	1600	2,0	1250	0,8	780	2430	1600	920	0,5
ATC 25	 Standardmodell	1900	1600	3,0-4,0	3000	1,7	950	2570	1500	1420	0,8
ATC 50	 Standardmodell	3150	2140	6,7	5000	3,0	1600	3600	2000	1540	2,0
ATC 50S		3150	2140	7,7	6000	3,6	1700	3600	2000	1740	2,0
ATC 50/2K		3150	2140	6,9	5000	3,0	1950	3600	2000	1540	2,0
ATC 60	 Standardmodell	3660	2140	7,7	6000	3,6	1800	4100	2000	1540	2,5
ATC 75	 Standardmodell	4150	2140	9,5	7500	4,6	2000	4600	2000	1540	3,0
ATC 75S		4150	2140	11,0	9000	5,4	2200	4600	2000	1740	3,0
ATC 75/2K		4150	2140	9,7	7500	4,5	2600	4600	2000	1540	3,0
ATC 100	 Standardmodell	5150 oder 4870	2140	12,5	10 000	6,0	2500	5600	2000	1540	4,0
ATC 100S		5150 oder 4870	2140	18,0	15 000	8,4	2800	5600	2000	2040	4,0
ATC 100/2K		5150 oder 4870	2140	12,7	10 000	6,0	2850	5600	2000	1540	4,0
ATC 100S Jumbo		5650	2400	24,0	20 000	12,0	4000	6550	2400	2070	5,0

Alle Container sind baumustergeprüft, TÜH abgenommen und tragen das GS-Zeichen (geprüfte Sicherheit).



Technische Änderungen behalten wir uns vor.

Containerabmessungen

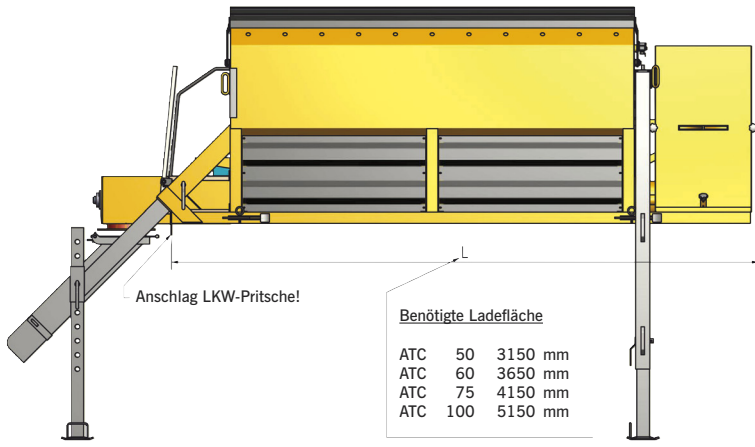

Benötigte Ladefläche

ATC	50	3150 mm
ATC	60	3650 mm
ATC	75	4150 mm
ATC	100	5150 mm

